

# UC2D90P

90 cm, TRIMODE - PREMIUM INDOOR, Model

BUILT-IN

UNDERCOUNTER® SERIE

*Fhiaba*



## FEATURES

- Made in Italy.
- Aisi 304 stainless steel body.
- Stainless steel interior finish
- Antibacterial stainless steel interior.
- Optiview: multi - LED light array (top and side interior) provides brilliant illumination to the entire interior.
- Soft close door and drawers in all compartments
- Smart OLED display
- Acoustic and visual signals
- Total no frost 100% automatic system
- Insulated variable speed compressors maintains precision temperature control with low vibration.
- Sabbath mode
- Front and rear adjustable feet up to 25 mm.
- Trimode system: Fhiaba patented Trimode drawers can be set to 3 different microclimates: freezer, fresco or fridge.
- Available size: 24", 30", 36".
- Chill to serve: you can rapidly lower the temperature to 2°C before serving.
- Fully integrated / custom panel ready
- Fully extractable drawers with soft closing guides
- Aisi 304 stainless steel interior
- Low vibration compressor
- Full range of models and configurations. Can easily be combined and configured with other Fhiaba fridge, freezer, wine cellar models to fit your kitchen needs.

## GENERAL PROPERTIES

Reversible door	NO
Equilance	NO
SoftClosing Runner	YES
Low vibration	YES
Optiview (LED light spots)	YES
Shelves	
Slide-out shelves	
Type of shelves	
Door Bins	
Fridge drawers type	
Fresco/LowTemp Drawers	
Bottom drawers	2
Full Extension shelves 90° door opening	NO
Full Extension drawers 90° door opening	YES
Defrost Process	AUTOMATIC
Ice maker with water filter	NO
Door Open Alarms	YES
Humidity control	NO
Active carbon filter	NO
Air filter control	NO
Shopping Fridge	NO
Shopping Freezer	YES
Power Failure Function	YES

# UC2D90P

90 cm, TRIMODE - PREMIUM INDOOR, Model  
BUILT-IN

UNDERCOUNTER® SERIE

## PRODUCT DETAIL

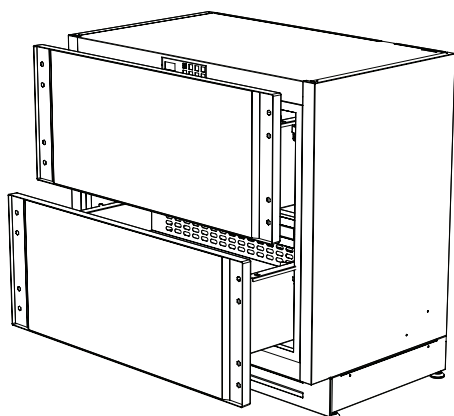

*Fhiaba*

2D

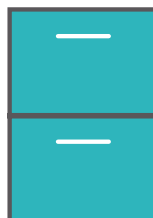

2BD | 1M

BD = drawer

M = separate microclimates

### CAPACITY

Volume Compartment 1 (L)	
Volume Compartment 2 (L)	
Volume Compartment 3 (L)	
Total Net Volume (L)	
Total Gross Volume (L)	
Compartment 1 / Upper wine cellar capacity (bottles)	
Compartment 2 / Lower wine cellar capacity (bottles)	
Undercounter glass shelf capacity (cans)	
Undercounter drawer capacity (cans)	
Undercounter bottom wooden bottle holder (bottles)	

### EFFICIENCY

New Energy Label class	
Energy consumption (kWh/year)	

### DIMENSIONS & WEIGHT

Height of the product (closed weels) (mm)	865
Adjustable feet height (mm)	25
Width of the product (mm)	898
Depth of Product without handle (mm)	572
Wall cavity height (mm)	870
Wall cavity width (mm)	900
Wall cavity depth (mm)	600
Net Weight (kg)	79
Gross Weight (kg)	94

### TECHNICAL DETAILS

Absorbed power (W)	
Total absorbed current (A)	2
Voltage (V)	220-240V
Frequency (Hz)	50-60 Hz
Power Cord Length (mm)	2
Plug Type	Schuko 16A
Climatic class	SN/T
Noise level (dB)	
Refrigerant (gas)	R600a
Water connection / female attachment	

### TEMPERATURE RANGES

Climatic compartments	1
Compartment 1 / Upper temperature (°C)	
Compartment 2 / Middle temperature (°C)	
Low temp zone	NO
Compartment 3 / Low temperature (°C)	from 8 to -22
Dual zone	NO

# UC2D90P

90 cm, TRIMODE - PREMIUM INDOOR, Model  
BUILT-IN

UNDERCOUNTER® SERIE

## PRODUCT SPECIFICATIONS AND DIMENSIONS

*Fhiaba*

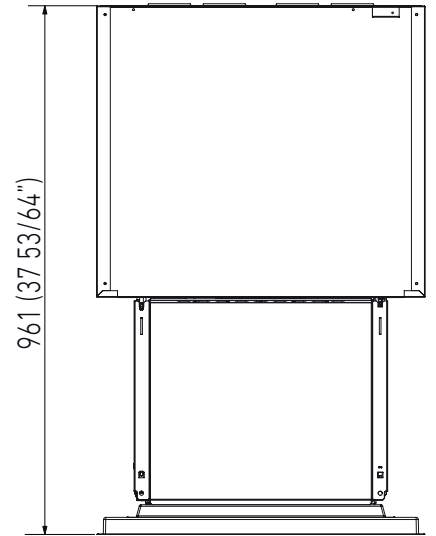
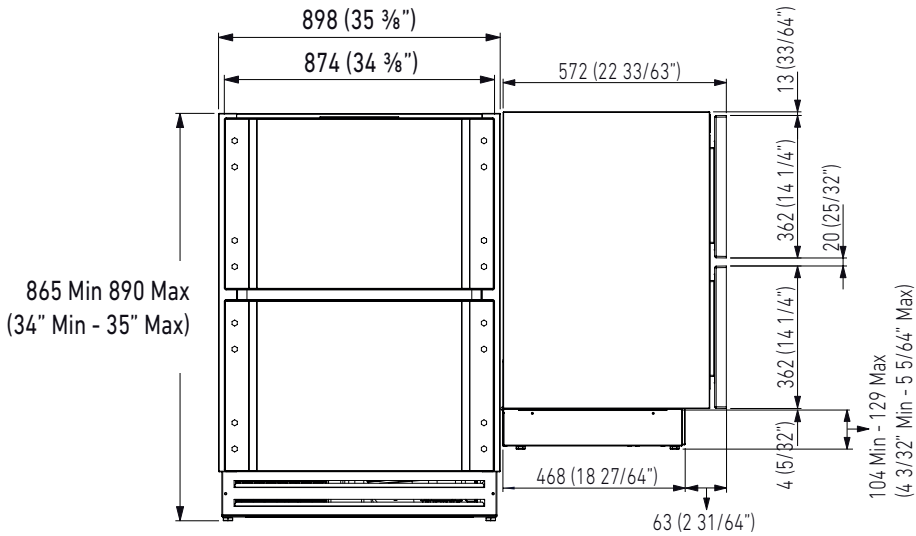

## Electrical and Water connection

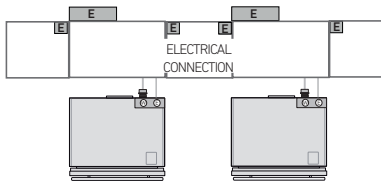

**i** For installation specifications, please consult with Fhiaba.  
For optimum installation, we recommend using the actual product as the best guide.

**i** Based on the adjustment of the feet and the height of the panel from the floor, the customer defines the perforated plinth to be installed on the equipment.

# UC2D90P

90 cm, TRIMODE - PREMIUM INDOOR, Model BUILT-IN

UNDERCOUNTER® SERIE

## NICHE SPECIFICATIONS AND DIMENSIONS

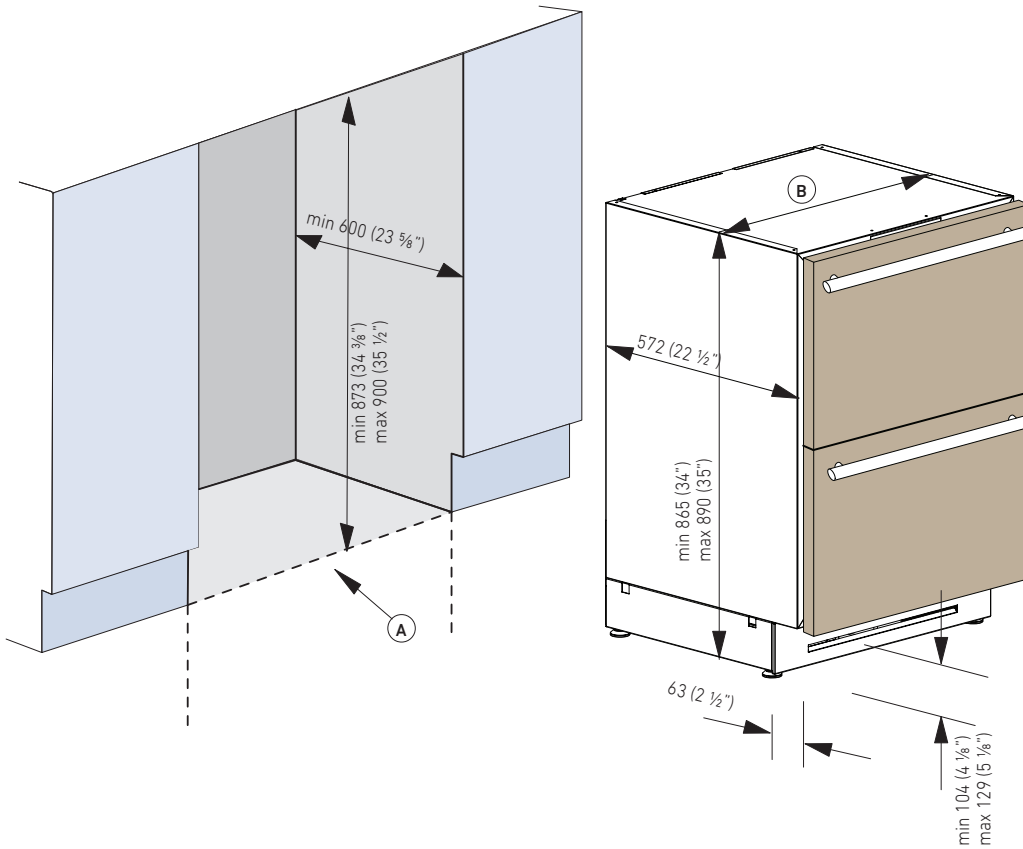

TECHNICAL DATA	
Niche Width <b>A</b> (mm)	900
Unit Width <b>B</b> (mm)	898

### Panel Dimensions

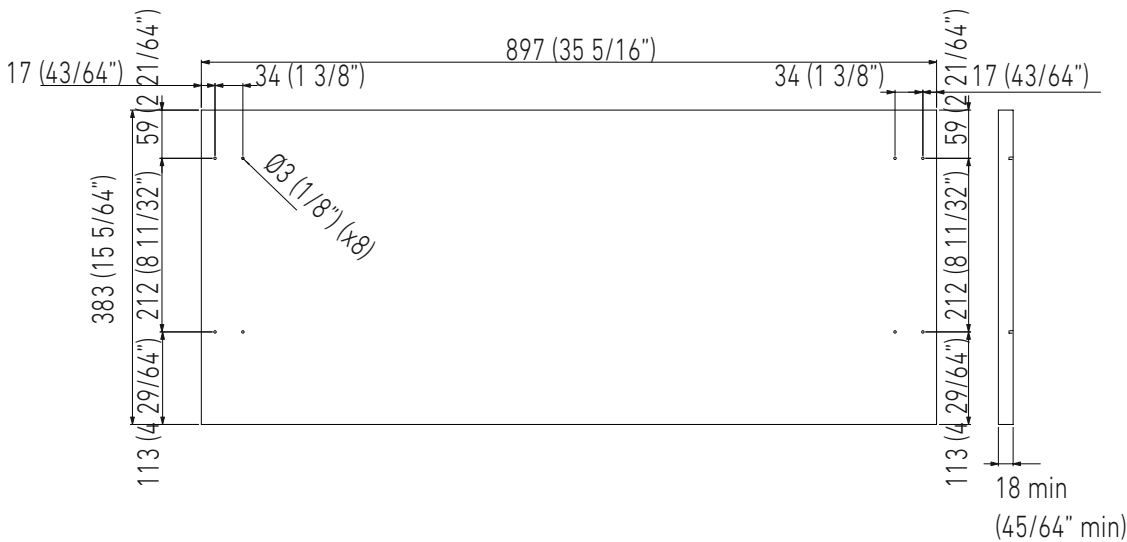

### Integrated Panel Recommendations

Panels with thickness ranging between 18 mm and mm.  
Panels with weight max of 12 kg. Provide installation of decorative panels during installation of the unit.

# UC2D90P

90 cm, TRIMODE - PREMIUM INDOOR, Model

BUILT-IN

UNDERCOUNTER® SERIE

## INSTALLATION INFORMATION

*Fhiaba*

### ACCESSORIES

- Stainless steel tubular handles 30mm
- Stainless steel tubular handles 18mm
- Stainless steel panels
- Extra length anti-tipping kit
- Cleaning kit
- 90° Door stop

 For installation specifications, please consult with Fhiaba.  
For optimum installation, we recommend using the actual product as the best guide.

     
[www.fhiaba.com](http://www.fhiaba.com)